



# Slope front

ice storage bin

---

## Features

Capacities available from 300 - 1000 lb (137 - 454 kg) and widths from 22.00" - 52.00" (55.9 - 132.1 cm)

### Convenient design

- extra large door opening for maximum access
- low sill height allows access to reach bottom of bin
- 22.00" (55.9 cm) and 30.00" (76.2 cm) bins match with compact ice machines to maximize ice production and storage in small space

### Durable construction

- full stainless top, front and sides standard
- heavy-duty welded steel shell and frame support
- poly-lined interior to eliminate corrosion
- rigid, insulated stainless steel lift door with non-staining ABS interior
- fully replaceable gasket seals door opening

### Easy installation

- comes assembled, simply screw in legs
- will fit through 32.00" (81.3 cm) doors (300-22 will fit through 23.00" (81.3 cm) doors)

---

## Accessories

- SmartCART™ 75 ice cart (item# 00112771)
- Ice paddle and hanging bracket (item# ABICEPADDL46)
- Plastic ice shovel (item# ABICESHOVEL)
- Stainless steel legs (item# ABSPECLEGS)
- Stainless steel back and bottom
- Partition
- Additional carts and accessories (refer to form 3435)

---

Job

---

Item

Follett Europe Polska Sp. z o.o.  
Mokry Dwór 26C 83-021 Wiślina, Poland  
+48 (58) 785-6140 | Fax: +48 (58) 785-6159  
folletteurope.com

801 Church Lane | Easton, PA 18040, USA  
1.610.252.7301 | Fax: +1.610.250.0696 | follettice.com

**FOLLETT**<sup>®</sup>  
Innovative solutions, inspired by ice

## Specification

Maximum bin capacity	see model table below
<b>W1</b> Width	see model table below
<b>D1</b> Depth	see model table below
<b>D2</b> Depth with door fully extended	add 10.00" (25.4 cm)
<b>H1</b> Height (adjustable)	see model table below
<b>H2</b> Bin sill height	see model table below
Required door access	see model table below
<b>L1</b> Drain <sup>1</sup>	1.00" FPT, center of bin bottom
Ice compatibility	all ice types up to 1.00" (2.54 cm) square, including flake ice type
Shipping weight	see model table below
NOTE: For indoor use only	

### SHORT FORM SPECIFICATION:

Ice storage bin to be Follett model \_\_\_\_\_. Bin to hold approximately \_\_\_\_\_ lb (kg) of ice. Construction to be welded steel shell and frame. Exterior finish to be stainless steel front and sides with galvanized steel back and bottom. Bin interior to have non-corroding polyethylene-lined walls and stainless steel bottom. Bin insulation to be non-CFC polyurethane foam, bonded to shell and polyethylene-lined walls for added structural strength. Bin top to be stainless steel and to be custom-cut for specific ice machine(s) to be used. Lift door to have stainless steel exterior and ABS interior, bonded together with non-CFC polyurethane foam for extra rigidity and strength. Bin to have conveniently low door sill height to allow easy access to ice in the bottom of the bin. Door opening to be completely sealed with fully replaceable gasketing. Bin to have 6.00" (15.24 cm) legs, adjustable to 6.75" (17.14 cm). Bin drain to be 1.00" FPT rigid PVC. NSF listed.

### Warranty:

Follett Corporation warrants to the original purchaser that the cabinet exterior, including the top and trim, and the interior liner will be free of corrosion for 3 years from the date of installation. Date of installation shall not exceed 90 days from date of shipment. Parts and labor for corrosion repair within this 3 year period are covered under this warranty. All other integral components are covered against defects in material and workmanship under normal use and service for 2 years from the date of installation. Date of installation shall not exceed 90 days from date of shipment. Parts and labor for repair within this 2 year period are covered under this warranty. Removal of ice machine to service bin and any labor costs incurred are expressly excluded from this warranty.

## Dimensional drawing

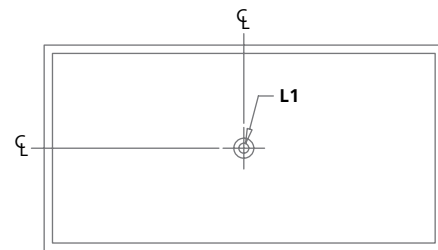
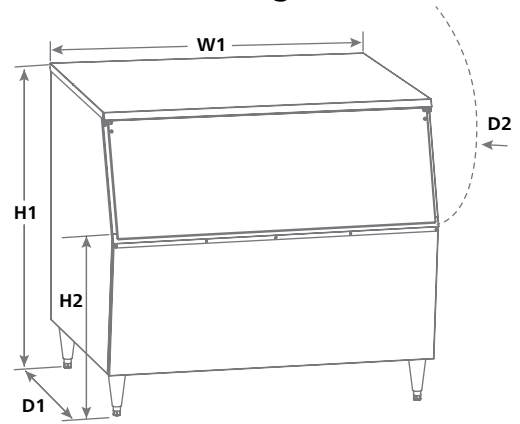

Horizon, Maestro and SmartCART are trademarks of Follett Corporation. Follett is a registered trademark of Follett Corporation, registered in the US. Follett reserves the right to change specifications at any time without obligation. Certifications may vary depending on country of origin.

Model	Maximum bin capacity lb (kg)	Cubic Volume cu ft (m)	Width - <b>W1</b> in (cm)	Depth - <b>D1</b> in (cm)	Height - <b>H1</b> in (cm)	Door Sill Height - <b>H2</b> in (cm)	Required door access in (cm)	Approximate ship weight lb (kg)
300-22*	300 (136)	9.6 (0.27)	22.00 (55.9)	29.50 (74.9)	40.00 (101.6)	26.00 (66.0)	23.00 (58.4)	128 (58)
425-30	430 (195)	13.8 (0.39)	30.00 (76.2)	29.50 (74.9)	40.00 (101.6)	26.00 (66.0)	31.00 (78.7)	144 (66)
650-44	660 (299)	20.8 (0.59)	44.00 (111.8)	29.50 (74.9)	40.00 (101.6)	26.00 (66.0)	32.00 (81.2)	178 (81)
950-48	950 (431)	30.1 (0.85)	48.00 (121.9)	28.25 (71.8)	50.00 (127.0)	36.00 (91.4)	32.00 (81.2)	207 (94)
1025-52	1030 (467)	32.6 (0.92)	52.00 (132.1)	28.25 (71.8)	50.00 (127.0)	36.00 (91.4)	32.00 (81.2)	217 (98)

### Notes:

\* Model 300-22 only for use with Follett® Maestro™ 400 (air-cooled) and Horizon™ 700 series ice machines.

<sup>1</sup> Follett recommends installation of a floor drain with grate with all ice storage bins.

