

# KM-1900S\_H(3)

## STACKABLE ICE CUBER

Item # \_\_\_\_\_

Project: \_\_\_\_\_

Qty: \_\_\_\_\_

\*AutoCad available on KCL

KM-1900S\_H(3)

11/13

Item # 13234

### CUBER DIMENSIONS

W x D x H

**KM-1900S\_H(3)**  
48 x 27<sup>3/8</sup> x 36<sup>7/16</sup>

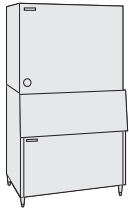

B-800

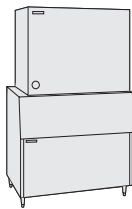

B-900

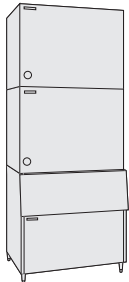

B-800

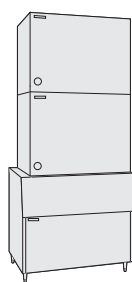

B-900

Also available on Large Bins:  
B-1150SS  
B-1300SS  
B-1500SS  
B-1650SS

### \*KM CUBE DIMENSIONS

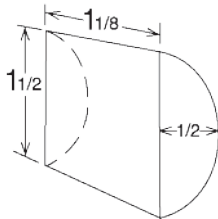

\*approximate size in inches, image not to scale

### KM-1900SAH

Air-Cooled 1 Phase  
Shown on an optional  
B-900

### KM-1900SAH3

Air-Cooled 3 Phase

### KM-1900SWH

Water-Cooled 1 Phase

### KM-1900SWH3

Water-Cooled 3 Phase

### KM-1900SRH

Remote Air-Cooled 1 Phase

### KM-1900SRH3

Remote Air-Cooled 3 Phase



- Up to 1903 lbs. of ice production per 24 hours

- Durable stainless steel exterior

- Protected by H-GUARD Plus Antimicrobial Agent 

- CycleSaver® design 

- EverCheck® alert system 

- Individual crescent cube

- Stainless steel evaporator

- Stackable for 3930 lbs. per 24 hour ice production in the same floor space

- Removable air filters (Air-cooled model only)

- R-404A Refrigerant

\* The KM-1900SAH, KM-1900SAH3, and KM-1900SRH are ENERGY STAR qualified.

### Warranty

Valid in United States, Canada, Puerto Rico, & U.S. Territories. Contact factory for warranty in other countries.

**Three Year** - Parts & Labor on entire machine.

**Five Year** - Parts & Labor on: Evaporator.

**Five Year** - Parts on: Compressor, air-cooled condenser coil.



15C9P001-15-01-001

© HOSHIZAKI AMERICA, INC.

618 Hwy. 74 S., Peachtree City, GA 30269

TEL 1-800-438-6087

FAX 1-800-345-1325

www.hoshizaki.com



# KM-1900S\_H(3) STACKABLE ICE CUBER

**DIMENSIONS**  
W x D x H  
**KM-1900S\_H(3)**  
48 x 27<sup>3/8</sup> x 36<sup>7/16</sup>

## STACKABLE ICE CUBER

- Air-cooled 1 phase / Air-cooled 3 phase
- Water-cooled 1 phase / Water-cooled 3 phase
- Remote Air-cooled 1 phase / Remote Air-cooled 3 phase

### AIR - COOLED 1 PHASE / 3 PHASE

Water Temp ° F.	50°	70°	90°
Air Temp ° F. 70°	1867 / 1859	1777 / 1763	1638 / 1633
Air Temp ° F. 80°	1798 / 1786	1659 / 1636	1511 / 1507
Air Temp ° F. 90°	1777 / 1763	<b>1560 / 1530</b>	1413 / 1398

### WATER - COOLED 1 PHASE / 3 PHASE

Water Temp ° F.	50°	70°	90°
Air Temp ° F. 70°	1876 / 1825	1868 / 1822	1734 / 1693
Air Temp ° F. 80°	1870 / 1823	1858 / 1818	1655 / 1619
Air Temp ° F. 90°	1868 / 1822	<b>1850 / 1814</b>	1673 / 1642

### REMOTE AIR - COOLED 1 PHASE / 3 PHASE

Water Temp ° F.	50°	70°	90°
Air Temp ° F. 70°	1857 / 1903	1793 / 1829	1636 / 1678
Air Temp ° F. 80°	1809 / 1847	1710 / 1731	1514 / 1552
Air Temp ° F. 90°	1793 / 1829	<b>1640 / 1650</b>	1457 / 1480

### UTILITY CONSUMPTION

Model Number	Ice Production Per Cycle		KWH per 100 LBS.	Potable Water Gal. per 100 lbs.	Condenser Water Gal. per 100 lbs.
	Lbs.	Cubes			
KM-1900SAH	45.3	2160	4.1	18.8	N/A
KM-1900SAH3	45.5	2160	4.1	17.0	N/A
KM-1900SWH	47.0	2160	3.1	18.8	99
KM-1900SWH3	45.4	2160	3.3	18.8	99
KM-1900SRH	46.0	2160	4.09	20.0	N/A
KM-1900SRH3	46.8	2160	4.04	20.9	N/A

### SPECIFICATIONS

Model Number	Condenser	Amperage	Min. Circuit Ampacity	Shipping Weight
KM-1900SAH	Air-Cooled	14.4	30	415 lbs.
KM-1900SAH3	Air-Cooled	8.6	20	415 lbs.
KM-1900SWH	Water-Cooled	12.5	30	415 lbs.
KM-1900SWH3	Water-Cooled	8.4	20	415 lbs.
KM-1900SRH	Remote Air-Cooled	14.9	30	415 lbs.
KM-1900SRH3	Remote Air-Cooled	11.0	20	415 lbs.

### STORAGE BINS

Model Number	Application Capacity	ARI-Rated Capacity
B-800	800 lbs.	600 lbs.
B-900	900 lbs.	660 lbs.
B-1150	1150 lbs.	N/A
B-1300	1275 lbs.	N/A
B-1500	1490 lbs.	N/A
B-1650	1605 lbs.	N/A

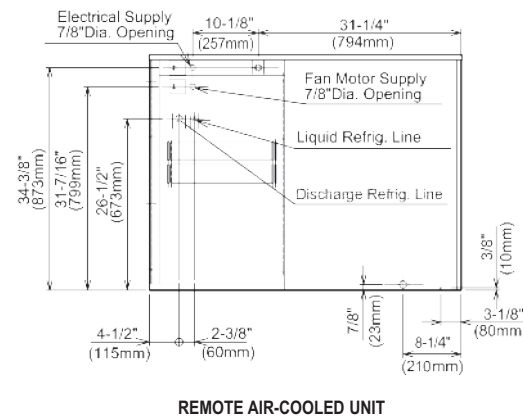
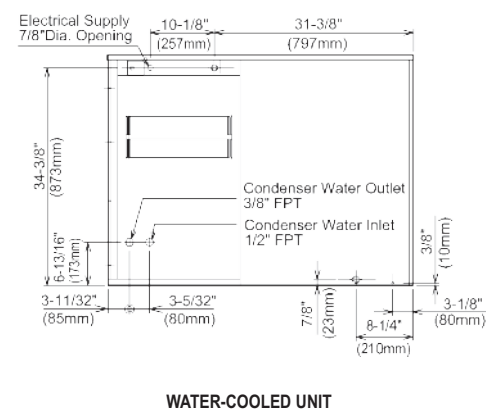
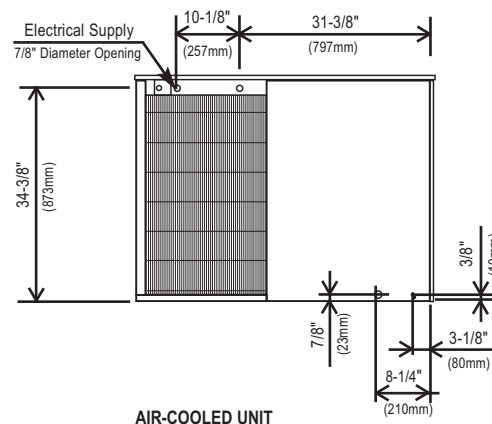
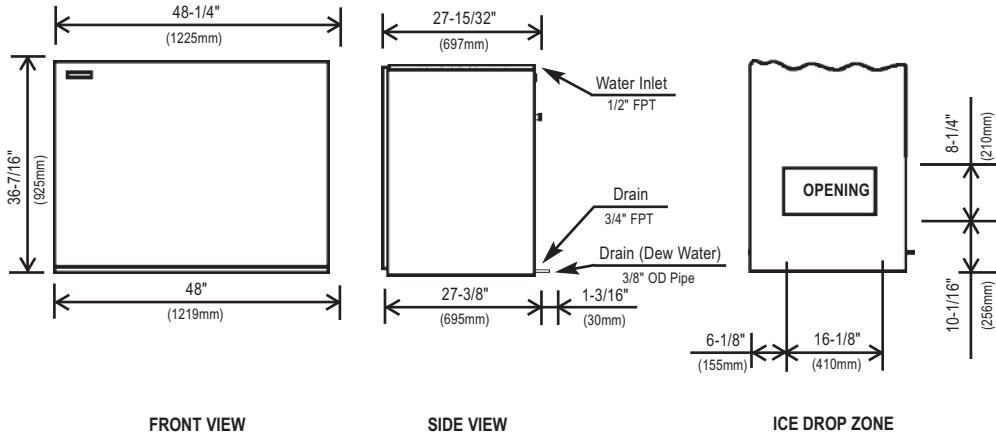

URC-22F Remote Condenser (Sold Separately)  
For Use with KM-1900SRH / KM-1900SRH3

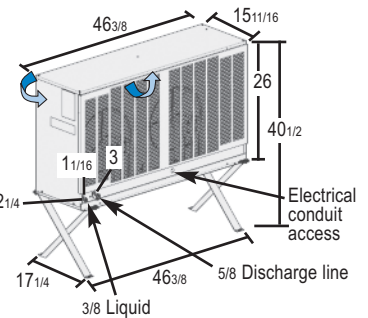

Pre-Charged Tubing Kits (Sold Separately)  
20' R404-20610  
35' R404-35610  
55' R404-55610

Voltage supply for the URC Remote Condenser is supplied from the Ice Maker. No additional circuit is required.

### ELECTRICAL & PLUMBING/KM-1900S\_H(3)

- KM-1900SAH / SVWH / SRH  
 • 208 - 230V/60/1ø (3 wire with neutral for 115V)  
 • 30 amp Max Fuse/HACR Breaker Size  
 KM-1900SAH3 / SVWH3 / SRH3  
 • 208 - 230V/60/3ø  
 • 20 amp Max Fuse/HACR Breaker Size  
 • 1/2" OD copper or equivalent independent potable water supply  
 • 3/4" FPT independent drain connection

### OPERATING LIMITS

- Ambient Temp Range 45 - 100° F
- Water Temp Range 45 - 90° F
- Water Pressure 10 - 113psig
- Voltage Range 187 - 253V

### SERVICE

- Panels easily removed and all components accessible for service.
- Removable/cleanable air filters (Air-cooled model only)

### CONDENSING UNIT

- Voltage Range 104 - 127V
- Ambient Temp Range -20 - 122° F



© HOSHIZAKI AMERICA, INC.

618 Hwy. 74 S., Peachtree City, GA 30269

TEL 1-800-438-6087

FAX 1-800-345-1325

www.hoshizaki.com

Printed in U.S.A.

